

200 SA

GIANT
FINISHING, INC.

Semi-Automatic Wastewater Treatment

Standard Features

- Semi-Automatic operation with manual overrides
- Maximum throughput 400 GPH
- 200-gallon treatment tank
- Allen-Bradley controls
- UL approved control panel
- 1 horsepower heavy duty agitator with jet basket
- Single addition automatic chemical feed hopper
- Bandfilter roller for greater dewatering
- 1/2 Cubic yard dumpster included
- Access platform included
- Stainless steel construction standard
- **Equipment Measurements:** Length: 9'0" Width: 5'8" Height: 8'2" Weight: approximately 1500 lbs.



Optional Features

- 2" Cast Iron Influent Diaphragm Pump
- Effluent Sump & Pump Package
- Equalization and Reuse Tanks

Giant's wastewater treatment units optimize the use of clay based flocculants to clarify industrial wastewaters.

GIANT FINISHING, 2040 N JANICE, MELROSE PARK, IL, 60160
PHONE (708) 343-6900 / (800) 404-4265 FAX (708) 343-6920
WWW.GIANTFINISHING.COM

200 SA

GIANT
FINISHING, INC.

Semi-Automatic Wastewater Treatment

Service Requirements

- E 480 VAC, 15 AMP, Grounded, 3 Phase Power Terminated at the Disconnect in the Control Panel.
- A 1/2" FNPT Air Supply Connection. 80-100 PSI, Clean, Dry, Air Required, With Locking Handle Valve on Service Line.
- I 2" FNPT Influent Water Inlet Connection.
- F 2" MNPT Effluent Water Discharge Connection.

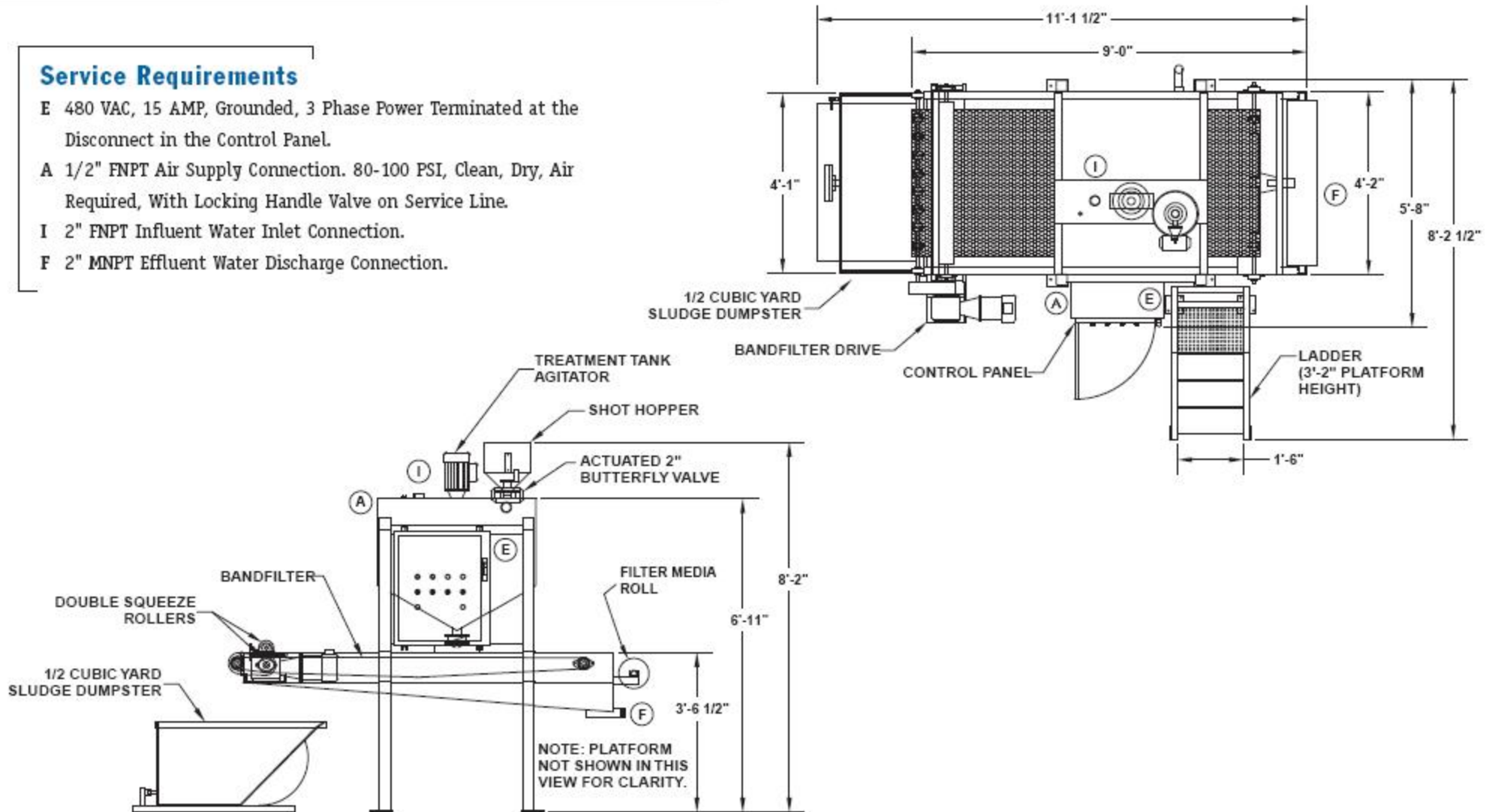

GIANT FINISHING, 2040 N JANICE, MELROSE PARK, IL, 60160
PHONE (708) 343-6900 / (800) 404-4265 FAX (708) 343-6920
WWW.GIANTFINISHING.COM